



MC13020

Motorola C-QUAM[®] AM Stereo Decoder

This circuit is a complete one ship, full feature AM stereo decoding and pilot detection system. It employs full-wave envelope signal detection at all times for the L + R signal, and decodes L - R signals only in the presence of valid stereo transmission.

- No Adjustments, No Coils
- Few Peripheral Components
- True Full-Wave Envelope Detection for L + R
- PLL Detection for L - R
- 25 Hz Pilot Presence Required to Receive L - R
- Pilot Acquisition Time 300 ms for Strong Signals, Time Extended for Noise Conditions to Prevent "Falsing"
- Internal Level Detector can be used as AGC Source

MOTOROLA C-QUAM[®] AM STEREO DECODER

SEMICONDUCTOR TECHNICAL DATA

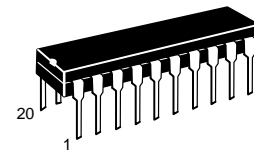

P SUFFIX
PLASTIC PACKAGE
CASE 738

ORDERING INFORMATION

Device	Operating Temperature Range	Package
MC13020P	T _A = -40 to +85°C	Plastic DIP

Figure 1. Simplified Application

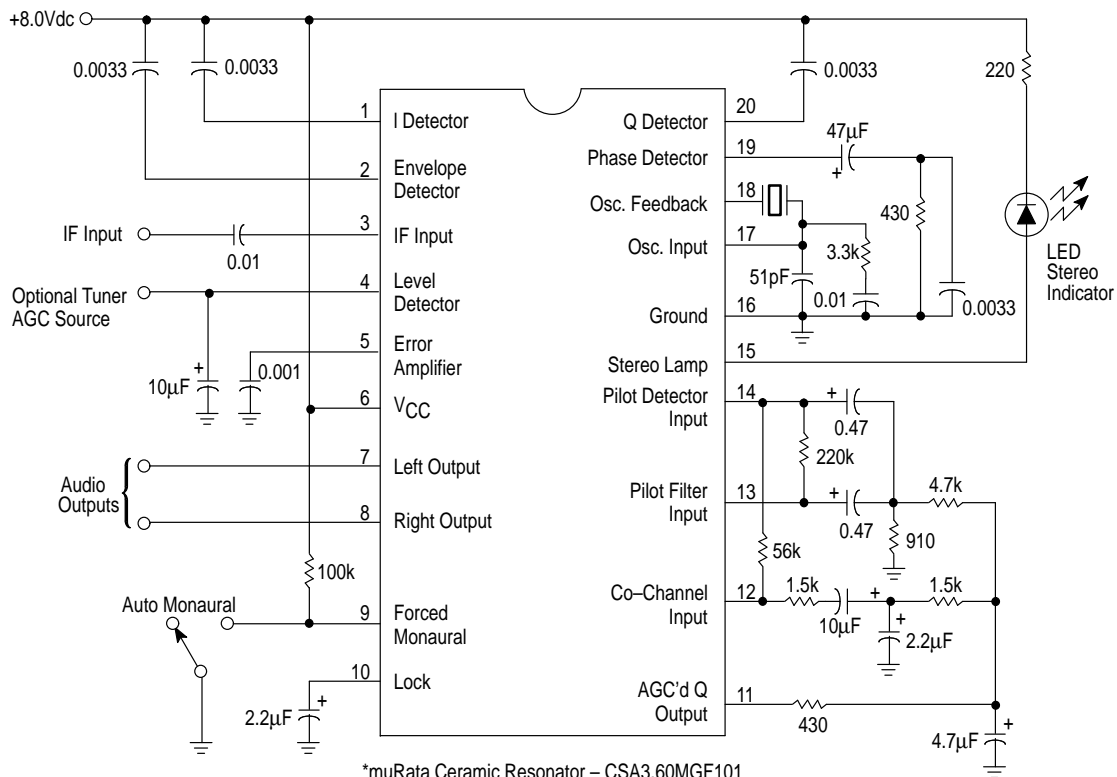

The purchase of the Motorola C-QUAM[®] AM Stereo Decoder does not carry with such purchase any license by implication, estoppel or otherwise, under any patent rights of Motorola or others covering any combination of this decoder with other elements including use in a radio receiver. Upon application by an interested party, licenses are available from Motorola on its patents applicable to AM Stereo radio receivers.

MC13020

MAXIMUM RATINGS

Rating	Symbol	Value	Unit
Supply Voltage	V_{CC}	14	Vdc
Pilot Lamp Current, Pin 15		50	mAdc
Operating Temperature	T_A	-40 to +85	°C
Storage Temperature	T_{stg}	-65 to +150	°C
Junction Temperature	$T_{J(max)}$	150	°C
Power Dissipation Derate above 25°C	P_D	1.25 10	W mW/°C

ELECTRICAL CHARACTERISTICS ($V_{CC} = 8.0$ Vdc, $T_A = 25^\circ\text{C}$, Input Signal = 200 mVrms. Unmodulated carrier, circuit of Figure 1, unless otherwise noted.)

Characteristics	Min	Typ	Max	Unit	
Supply Line Current Drain, Pin 6	20	30	40	mAdc	
Input Signal Level, Unmodulated, Pin 3, for Full Operation	112	200	357	mVrms	
Audio Output Level, 50% Modulation	L only or R only 80	220 110	280 140	mVrms	
Channel Balance, 50% Modulation, Monaural	-	-	± 1.0	dB	
Output THD, 50% Modulation				%	
	Monaural	-	0.5		
	Stereo	-	1.0		
Output THD, 90% Modulation	Monaural	-	1.0		
Channel Separation, L only or R only, 50% Modulation	23	30	-	dB	
Input Impedance	R_{in} C_{in}	20 6.0	- -	k Ω pF	
Output Impedance	-	100	150	Ω	
Pilot Acquisition Time		280	300	ms	
VCO locked (after release of forced monaural)	-	-	-	sec	
Bad Signal Condition	1.48	-	-		
Lock Detector Filter Voltage, Pin 10	In Lock Out of Lock	7.7 -	8.0 0.8	- 1.0	Vdc
Force to Monaural, Pin 9					
Pull-Down for Monaural Mode	2.0 -	2.5 0.15	- 1.0	Vdc μA	
Pull-Up for Automatic Mode	- -	3.5 <0.001	3.7 1.0	Vdc μA	

Figure 2. Basic Quadrature AM (QUAM)

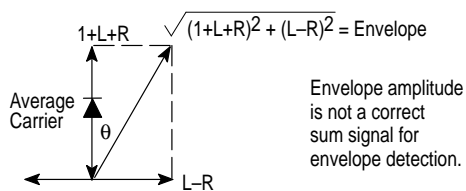

Figure 3. Motorola C-QUAM[®]

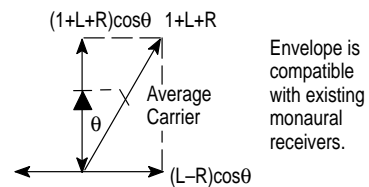
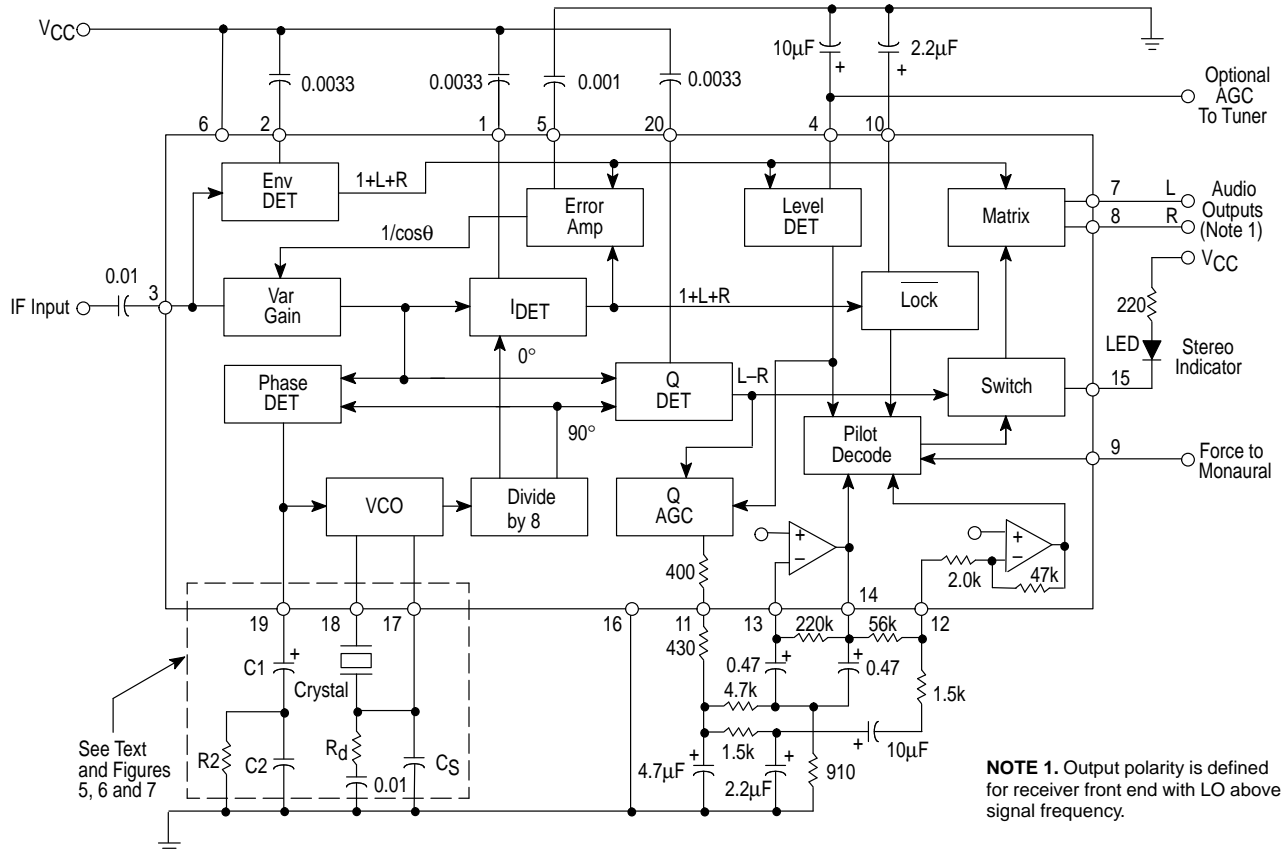

Figure 4. Representative Block Diagram



MOTOROLA C-QUAM® – COMPATIBLE QUADRATURE AM STEREO

Introduction

In C-QUAM®, conventional quadrature amplitude modulation has been modified by multiplying each axis by $\cos\theta$ as shown in Figures 2 and 3. The resulting carrier envelope is $1 + L + R$, i.e., a correct sum signal for monaural receivers and for stereo receivers operating in monaural mode. A 25 Hz pilot signal is added to the $L - R$ information at a 4% modulation level.

Decoder

The MC13020P takes the output of the AM IF amplifier and performs the complete C-QUAM® decoding function. In the absence of a good stereo signal, it produces an undegraded monaural output. Note in Figure 4 that the $L + R$ information delivered to the output always comes from the envelope detector (Env DET).

The MC13020P decodes the stereo information by first converting the C-QUAM® signal to QUAM, and then detecting QUAM. The conversion is accomplished by comparing the output of the Env DET and the I DET in the Err AMP. This provides $1/\cos\theta$ correction factor, which is then multiplied by the C-QUAM® incoming signal in the Var Gain block. Thus, the output of the Var Gain block is a QUAM signal, which can then be synchronously detected by conventional means. The I and Q detectors are held at 0° and

90° relative demodulation angles by reference signals from the phase-locked, divided-down VCO. The output of the I DET is $1 + L + R$, with the added benefit (over the Env DET) of being able to produce a negative output on strong co-channel or noise interference. This is used to tell the Lock circuit to go to monaural operation. The output of the Q DET is the $L - R$ and pilot information.

VCO

The VCO operates at 8 times the IF input frequency, which ensures that it is out-of-band, even when a 260 kHz IF frequency is used. Typically, a 450 kHz IF frequency is used with synthesized front ends. This places the VCO at 3.6 MHz, which permits economic crystal and ceramic resonators. A crystal VCO is very stable, but cannot be pulled very far to follow front-end mis-tuning. Pull-in capability of ± 100 Hz at 450 kHz is typical, and de-Q-ing with a resistor (see Figure 7) can increase the range only slightly. Therefore, the crystal approach can only be used with very accurate, stable front-ends. By comparison, ceramic and L-C VCO circuits offer pull-in range in the order of ± 2.5 kHz (at 450 kHz). Ceramic devices accurate enough to avoid trimming adjustment can be obtained with a matched capacitor for Cs (see Figure 1 and 5).

In the PLL filter circuit on Pin 19, C1 is the primary factor in setting a loop corner frequency of 8.0 to 10 Hz, in-lock. An internally controlled fast pull-in is provided. R2 is selected to slightly overdamp the control loop, and C2 prevents high frequency instability.

The Level DET block senses carrier level and provides an optional tuner AGC source. It also operates on the Q AGC block to provide a constant amplitude of 25 Hz pilot at Pin 11, and it delivers information to the pilot decoder regarding signal strength.

Pilot and Co-Channel Filters

The Q AGC output drives a low pass filter, made up of 400 Ω internal and 430 Ω and 5 μF external. From this point, an active 25 Hz band-pass filter is coupled to the Pilot Decoder, Pin 14, and another low-pass filter is connected to the Co-channel Input, Pin 12. A 2:1 reduction of 25 Hz pilot level to the Pilot Decode circuit will cause the system to go monaural, with the components shown. Refer to Figure 8 for the formulas governing the active band-pass filter. The co-channel input signal contains any low frequency intercarrier beat notes, and, at the selected level, prevents the Pilot Decode circuit from going into stereo. The co-channel input, Pin 12, gain can be adjusted by changing the external 1.5 k resistor. The values shown set the "trip" level at about 7% modulation. The 25 Hz pilot signal at the output of the active filter is opposite in phase to the pilot signal coming from the second low-pass filter. The 56 k resistor from Pin 14 to Pin 12 causes the pilot to be cancelled at the co-channel input. This allows a more sensitive setting of the co-channel trip level.

Pilot Decoder

The Pilot Decoder has two modes of operation. When signal conditions are good, the decoder will switch to stereo after 7 consecutive cycles of the 25 Hz pilot tone. When signal conditions are bad, the detected interference changes the pilot counter so as to require 37 consecutive cycles of pilot to go to stereo. In a frequency synthesized radio, the logic that mutes the audio when tuning can be connected to Pin 9. When this pin is held low it holds the decoder in monaural mode and switches it to the short count. This pin should be held low until the synthesizer and decoder have both locked onto a new station. A 300 ms delay should be sufficient. If the synthesizer logic does not provide sufficient delay, the circuit shown in Figure 9 may be added. Once Pin 9 goes high, the Pilot Decoder starts counting. If no pilot is detected for seven consecutive counts, it is assumed to be a good monaural station and the decoder is switched to the long count. This reduces the possibility of false stereo triggering due to signal level fluctuation or noise. If the PLL goes out of lock, or interference is detected by the co-channel protection circuit before seven cycles are counted, the decoder goes into the long count mode. Each disturbance will reset the counter to zero. The Level Detector will keep the decoder from going into stereo if the IF input level drops 10 dB, but will not change the operation of the pilot counter.

Once the decoder has gone into the stereo mode, it will go instantly back to monaural if either the lock detector on Pin 10 goes low, or if the carrier level drops below the present threshold. Seven consecutive counts of no pilot will also put the decoder in monaural. In stereo, the co-channel input is

disabled, and co-channel or other noise is detected by negative excursions of the I DET, as mentioned earlier. When these excursions reach a level caused by approximately 20% modulation of co-channel, the lock detector puts the system in monaural, even though the PLL may still actually be locked. This higher level of co-channel tolerance provides the hysteresis to prevent chattering in and out of stereo on a marginal signal.

When all inputs to the Pilot Decode block are correct, and it has completed its count, it turns on the Switch, sending the L - R to the Matrix, and switches the pilot lamp pin to a low impedance to ground.

Summary

It should be noted that in C-QUAM®, with both channels AM modulated, the noise increase in stereo is a maximum of 3.0 dB, less on program material. Therefore, this is not the major concern in the choice of monaural to stereo switching point as it was in FM, and blend is not needed.

PIN FUNCTION DESCRIPTION

Pin	Description
1, 2	Detector Filters, $R_{\text{out}} = 4.3 \text{ k}$, recommend 0.0033 μF to V_{CC} to filter 450 kHz components.
3	IF Signal Input
4	Level Detector filter pin, $R_{\text{out}} = 8.2 \text{ k}$, 10 μF to ground sets the AGC time constant. High impedance output, needs buffer.
5	Error Amp compensation to stabilize the Var Gain feedback loop
6	V_{CC} , 6.0 to 10 Vdc, suitable for low V_{bat} automotive operation, but must be protected from "high line" condition.
7, 8	Left and Right Outputs, NPN emitter-followers
9	Forced Monaural, MOS or TTL controllable
10	Lock detector filter, $R_{\text{out}} = 27 \text{ k}$, recommend 2.2 μF to ground
11	AGC'd Q output, NPN emitter-follower with 400 Ω from emitter to Pin 11
12	Co-channel input, 2.0 k series in and 47 k feedback
13	Pilot Filter input to op amp, see Figure 8.
14	Pilot Decode Input (op amp output) emitter-follower, $R_{\text{out}} = 100 \Omega$
15	Stereo Lamp, open-collector of an NPN common emitter stage, can sink 50 mA, $V_{\text{sat}} = 0.3 \text{ V}$ at 5.0 mA.
16	Ground
17	Oscillator input, $R_{\text{in}} = 10 \text{ k}$, do not DC connect to Pin 18 or ground.
18	Oscillator feedback, NPN emitter, $R_{\text{out}} = 100 \Omega$
19	Phase Detector output, current source to filter.
20	Detector Filter, $R_{\text{out}} = 4.3 \text{ k}$, recommend 0.0033 μF to V_{CC} to filter 450 kHz.

Figure 5. Ceramic VCO

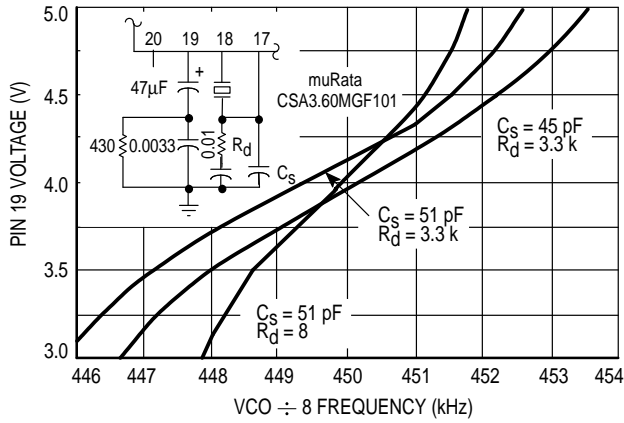

Figure 6. L-C VCO

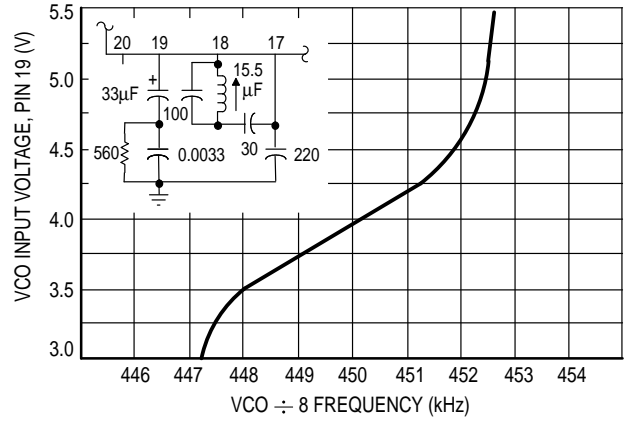

Figure 7. Crystal VCO

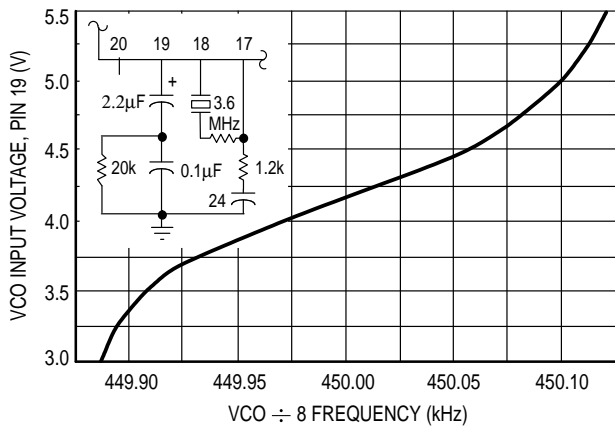

Figure 8. Forced Monaural Optional Delay Circuit

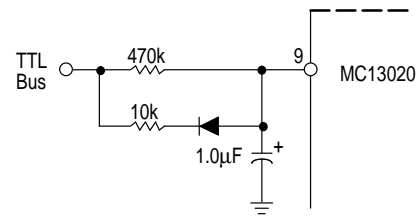
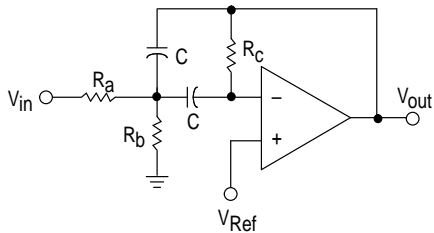

Figure 9. Active Bandpass Filter



$$R_c = \frac{Q}{\pi f_0 C}$$

$$R_a = \frac{R_c}{2 A_0}$$

$$R_b = \frac{R_a R_c}{4Q^2 R_a - R_c}$$

C ± 5%	R _a ± 5%	R _b ± 1%	R _c ± 1%
0.47 µF	4.7 k	910	220 k
0.33 µF	8.2 k	1.3 k	330 k

NOTE: Capacitor C should be a good grade, low ESR.

Where in this application: f_0 = center frequency = 25 Hz
 A_0 = gain at $f_0 \leq 25$
 $Q \leq 10$

Choose values for f_0 , A_0 , Q , and convenient C , solve for resistors.

MC13020

OUTLINE DIMENSIONS

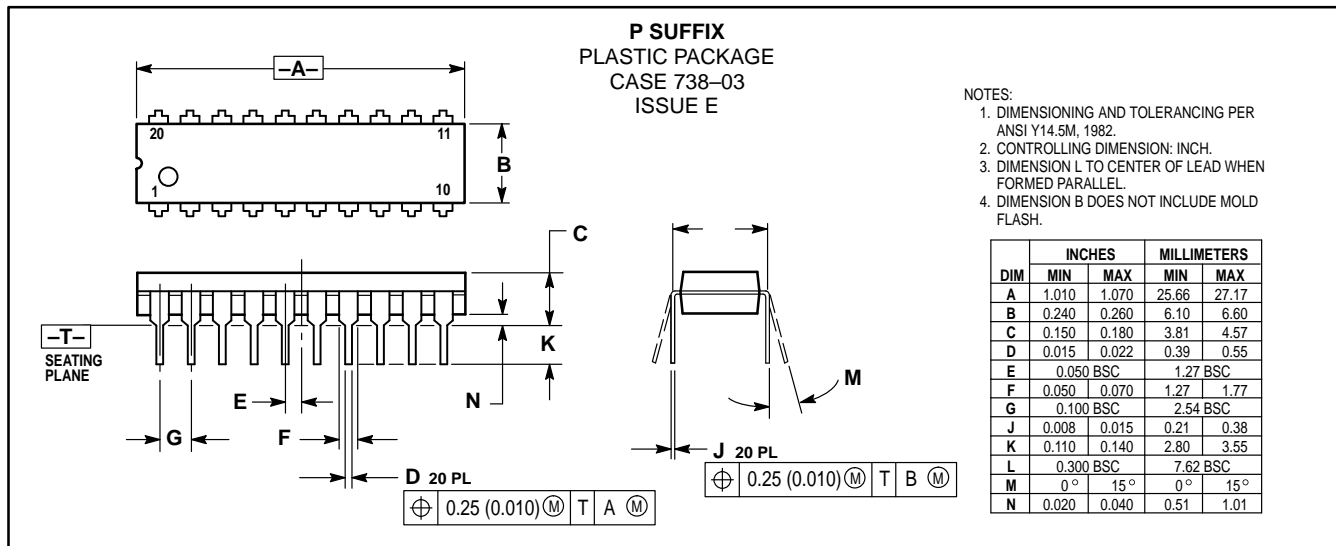

Motorola reserves the right to make changes without further notice to any products herein. Motorola makes no warranty, representation or guarantee regarding the suitability of its products for any particular purpose, nor does Motorola assume any liability arising out of the application or use of any product or circuit, and specifically disclaims any and all liability, including without limitation consequential or incidental damages. "Typical" parameters can and do vary in different applications. All operating parameters, including "Typicals" must be validated for each customer application by customer's technical experts. Motorola does not convey any license under its patent rights nor the rights of others. Motorola products are not designed, intended, or authorized for use as components in systems intended for surgical implant into the body, or other applications intended to support or sustain life, or for any other application in which the failure of the Motorola product could create a situation where personal injury or death may occur. Should Buyer purchase or use Motorola products for any such unintended or unauthorized application, Buyer shall indemnify and hold Motorola and its officers, employees, subsidiaries, affiliates, and distributors harmless against all claims, costs, damages, and expenses, and reasonable attorney fees arising out of, directly or indirectly, any claim of personal injury or death associated with such unintended or unauthorized use, even if such claim alleges that Motorola was negligent regarding the design or manufacture of the part. Motorola and are registered trademarks of Motorola, Inc. Motorola, Inc. is an Equal Opportunity/Affirmative Action Employer.

How to reach us:

USA / EUROPE: Motorola Literature Distribution;
P.O. Box 20912; Phoenix, Arizona 85036. 1-800-441-2447

MFA: RMFAX0@email.sps.mot.com - TOUCHTONE (602) 244-6609
INTERNET: http://Design-NET.com

JAPAN: Nippon Motorola Ltd.; Tatsumi-SPD-JLDC, Toshikatsu Otsuki,
6F Seibu-Butsuryu-Center, 3-14-2 Tatsumi Koto-Ku, Tokyo 135, Japan. 03-3521-8315

HONG KONG: Motorola Semiconductors H.K. Ltd.; 8B Tai Ping Industrial Park,
51 Ting Kok Road, Tai Po, N.T., Hong Kong. 852-26629298

